

# Technical What's New

**Autodesk<sup>®</sup>**  
**Inventor<sup>™</sup>**

2008

Inventor Suite

Inventor Simulation Suite

Inventor Routed Systems Suite

Inventor Professional



**Autodesk**

# Technical What's New

## Contents

<b>Sheet Metal Design</b> .....	4	<b>AliasStudio Interoperability</b> .....	12	<b>Flanged and Welded Pipe Styles</b> .....	15
Sheet Metal Design Tools.....	4	<b>Dynamic Simulation</b> .....	12	Flanged Pipe Runs.....	15
Flat Pattern Modification.....	4	Automatic Joint Creation.....	12	Butt Weld Pipe Runs.....	15
Table Driven Punch Definition.....	4	Stress Analysis Integration.....	12	Tube and Pipe Styles Editor.....	15
Bend and Punch Tables.....	4	Export Trace Curves to a Sketch.....	12	<b>Ribbon Cables</b> .....	15
Customized Flat Pattern Output.....	5	Enhanced 2D Contact Capabilities.....	12	Ribbon Cable Design.....	15
<b>Drawing Manager</b> .....	5	Usability Enhancements.....	12	Cable Connector Authoring.....	16
Isometric View Dimensioning.....	5	<b>Finite Element Analysis</b> .....	13	Connector Placement on Nailboard Drawings..	16
Drawing Views.....	6	Stress Analysis for Thin Wall Parts.....	13	Cable and Harness Performance/Capacity.....	16
Revision Tables and Tags.....	6	Feature Suppression for Stress Analysis.....	13	<b>Import Export</b> .....	16
Dimensions and Notes.....	7	Multiple Time Step Analysis.....	13	Import.....	16
Other Enhancements.....	7	<b>Frame Design</b> .....	13	Export.....	16
<b>DWG TrueConnect</b> .....	7	Parametric Frame Layout.....	13	<b>Construction Environment</b> .....	16
View, Plot, and Measure Using AutoCAD.....	7	Improved Cut Treatments.....	13	<b>Inventor Studio</b> .....	16
Saving Inventor Drawings as DWG Files.....	7	Improved Frame Editing.....	13	<b>DWF Publishing and Design Review</b> .....	17
Opening AutoCAD DWG Files with Inventor.....	7	Other Enhancements.....	13	Comprehensive 2D and 3D Publishing.....	17
Shared Objects.....	8	<b>Design Accelerators</b> .....	13	DWF Design Review.....	17
AutoCAD Blocks in Inventor.....	8	Shaft Generator.....	13	Security Management.....	17
Additional Highlights.....	8	Roller Chain Generator.....	14	Bill of Materials Output.....	17
DWG Import Tool.....	8	Spring Generators.....	14	Work Instructions.....	17
Comparison of Enhanced DWG Support with Translation.....	8	Beam and Column Calculator.....	14	<b>Content Center</b> .....	17
<b>Sketch Productivity</b> .....	8	Limits and Fits Calculator.....	14	BOM Document Setting Support.....	17
Enhanced Sketch Constraints.....	8	<b>Assemblies</b> .....	14	AutoDrop On-Off Option.....	17
Sketch Edit Tools.....	9	Improved Design Doctor Feedback on Conflicting Constraints (AUGI #1).....	14	Side by Side Installation.....	17
Geometry Formatting Tools.....	9	Multiple File Open and Place (AUGI #9).....	14	Improved Library Configuration.....	17
<b>Enhanced User Interface</b> .....	9	Default Level of Detail.....	14	Performance Improvements.....	17
Productivity Enhancements.....	10	Infer iMates from Constraints.....	14	<b>MDT Compatibility</b> .....	18
Application Consistency and Ease of Use.....	10	Optimized Selection for Selection Prehighlight... ..	14	<b>Stay Up to Date</b> .....	18
<b>Shape Design</b> .....	10	Skeletal Modeling.....	14	Subscription.....	18
Part Modeling Tools.....	10	Derived Assembly.....	15	Product Updates.....	18
Measure and Analysis Tools.....	11	Delayed Migration.....	15	Feedback.....	18
Quality and Performance.....	11	Other Enhancements.....	15	<b>Conclusion</b> .....	18

# Technical What's New

## Welcome to Inventor 2008

The Autodesk® Inventor™ product line is the best choice for AutoCAD® software users. It provides a comprehensive, integrated set of design tools for manufacturing companies including Autodesk® Inventor™ Suite for 3D design and documentation, Autodesk® Inventor™ Professional for creating routed systems and validating designs, AutoCAD® Mechanical for 2D drawing and detailing, and Autodesk® Vault for data management.

The Inventor product line delivers enhanced 3D productivity while preserving 2D engineering designs through true DWG™ compatibility. Inventor also delivers a new groundbreaking modeling paradigm, Functional Design. Functional Design allows designers to move beyond geometric modeling and into an environment where they can focus on the problem they are trying to solve rather than spending time solely on the 3D geometry required to build the design.

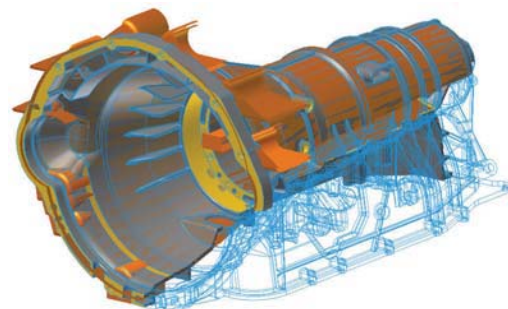
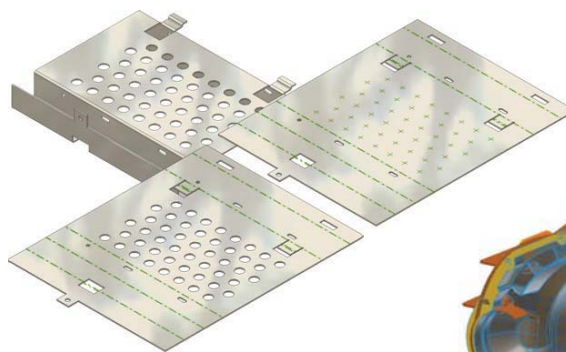
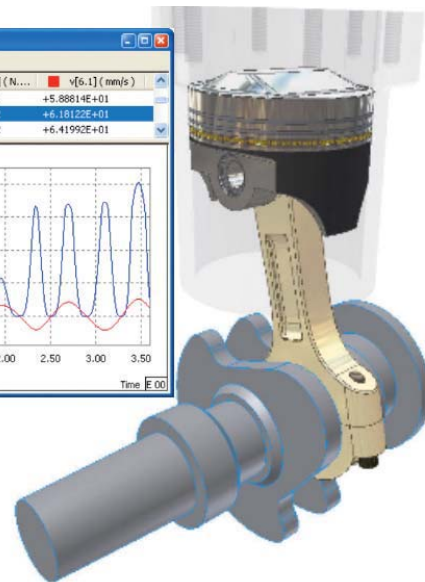
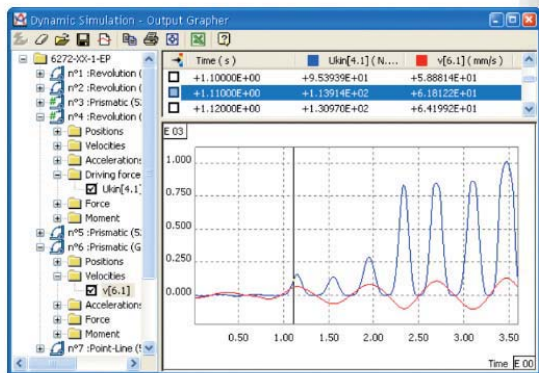

# Technical What's New

## Sheet Metal Design

The sheet metal environment in Inventor 2008 has been upgraded to improve productivity when designing sheet metal parts and to provide support for manufacturing information including flat pattern modifications and punch tool data.

### Sheet Metal Design Tools

#### Improved Flange and Contour Flange Tools

Both tools have been redesigned to reduce the number of steps required to create flanges and contour flanges.

The Flange and Contour Flange tools enable designers to create multiple flanges in a single feature with support for nonadjacent edges of a face, and automatic mitering of adjacent flanges/contour flanges. Both tools include comprehensive options for controlling bend position and height.

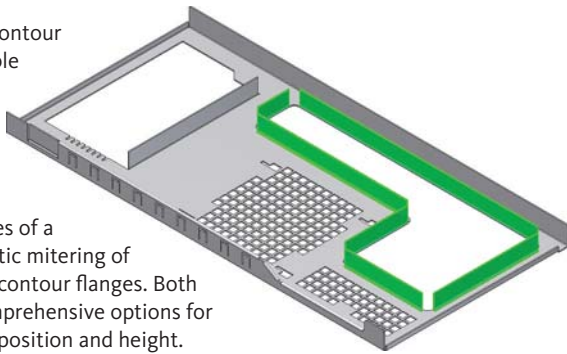

#### Improved Corner Tool

With the new Corner tool users can now define corner overlap conditions using the same aligned dimension used in the Flange and Contour Flange tools. The default corner option for three bend intersections can be modified by selecting from one of four options: none, intersection, round, and round with radius.

#### Cut Across Bend

The Cut feature now supports partial thickness cut depths in conjunction with the cut across bend option.

### Flat Pattern Modification

The new flat pattern environment is shown in the browser with separate feature trees for the folded and unfolded states. Features added to the flat pattern do not affect the folded model, allowing the flat pattern to be modified using standard part modeling features.

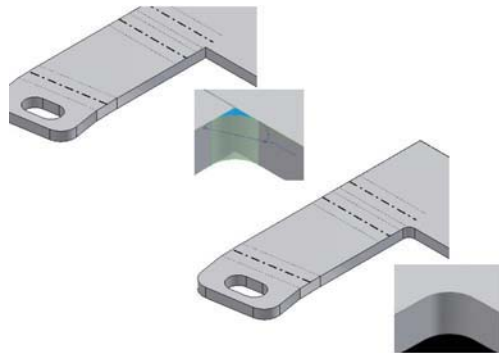

Both the folded model and flat pattern are displayed in the same graphics window, and designers can quickly switch between the two by clicking on the appropriate browser node.

The new Edit Flat Pattern Definition tool simplifies the definition of flat pattern orientation. The same tool provides access to Punch Definition where users can override the default punch representation defined in the sheet metal style. Users can also add punch features in the flat pattern to incorporate proprietary manufacturing methods.

### Table Driven Punch Definition

Table driven punch definition enables the characterization of families of punches, typically different sizes of the same punch shape with full representation of manufacturing parameters including punch ID, punch depth, and sketches for alternate punch representations. Punch depth represents the throw depth of the tool and can be tied to sheet metal thickness by incorporating a formula in the punch definition.

Punch tools are defined as a specialized subtype of iFeature. The punch tool subtype incorporates checks to confirm that the iFeature contains a valid center mark required for the creation of drawings and DXF™ files for manufacturing.

### Bend and Punch Tables

With the new Bend and Punch tables users can quickly create accurate manufacturing drawings to support sheet metal manufacturing operations.

Key manufacturing information such as bend angles and radii as well as punch direction, punch angle, punch ID, and punch tool depth captured in the 3D model can be inserted directly in the Inventor drawing using a single command. Drawing Manager supports alternate punch representations and annotation of bend directions using drawings styles for bend line style.

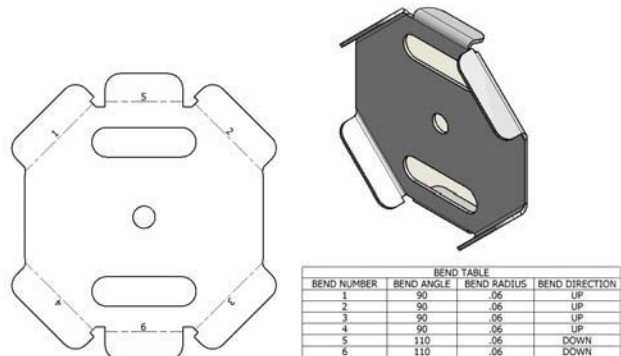

# Technical What's New

## Customized Flat Pattern Output

A new export tool in Inventor 2008 gives better access to pre- and postprocessing options to simplify the creation of DXF and DWG export files for sheet metal. Capabilities include:

- DXF/DWG File Version Specification.
- External XML File definition supports customized post processing operations for flat pattern output.
- Layer mapping and export control for deleting and renaming layers during export.
- Spline simplification options utilizing linear approximation to create linear segments for driving computer numeral controlled (CNC) equipment that can't consume splines.
- Inner and outer contour merging into polylines for wire burning and other polyline path based manufacturing methods.
- Geometry rebasing allows all geometry to be moved into positive coordinate space as required by some CNC machines.
- Savable export configuration files for reuse and API (application programming interface) access.
- Full API support for controlling all DXF/DWG flat pattern output.

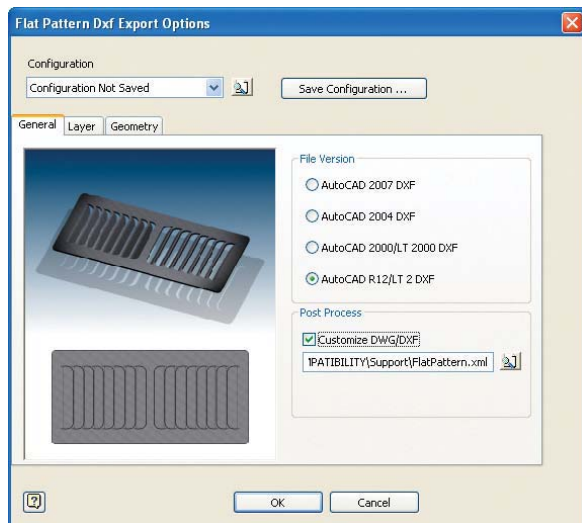

## Drawing Manager

A large number of enhancements are incorporated in the Inventor 2008 Drawing Manager to address customer enhancement requests and improve support for international drawing standards.

## Isometric View Dimensioning

The General Dimension tool has been extended to support dimensions on isometric views with full support for linear, angular, radial, diameter, and arc length dimensions. The workflow is similar to placing dimensions on an orthographic view except that the dimension is placed on the appropriate isometric plane. In cases such as linear dimensions, where there is more than one valid plane, users can toggle through the valid options using the spacebar and then click to place the dimension in the most appropriate plane.

Users can also define annotation planes in the model and use them to control the placement of isometric view dimensions. Annotation planes are fully parametric so any change to the plane will modify the location of the isometric view dimensions.

Isometric view dimensions support the same formatting and edit capabilities as the existing orthographic dimensions including inspection dimensions.

Designers can use isometric view dimensions to rapidly created dimensioned tube and pipe drawings by dimensioning to the 3D sketch geometry that defines the pipe routes.

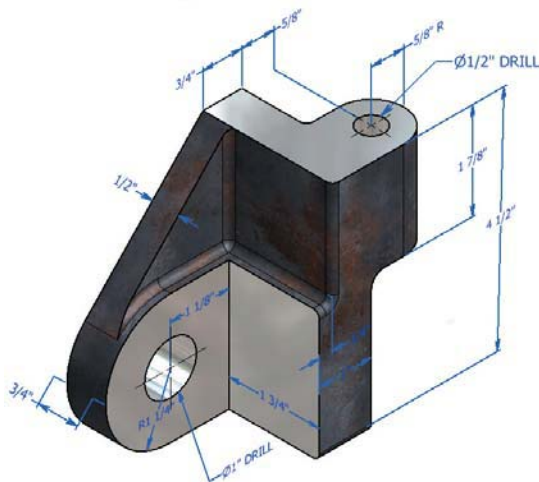

# Technical What's New

## Drawing Views

Enhancements to the view tools provide additional flexibility and control reducing the time required to create drawings containing complex detail and cut views.

### View visibility

Hide an entire view without having to drag it off the sheet. Simply right click on the view—either in the graphics window or the browser—and click the visibility checkbox to hide the view.

### Crosshatch by material type

The new Material Hatch Pattern Defaults tab, located in the Default Standard style, defines the mapping between material type and hatch pattern. Inventor references this table when creating section and break-out views and applies the correct hatch pattern to each face resulting from the cut operation.

Inventor provides two options to minimize the time needed to set up the Hatch Pattern Defaults. Material names can be read directly from the active style library, or they can be read from the material definitions stored in a specific part file.

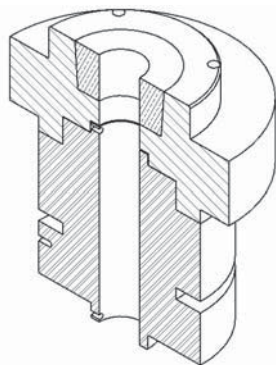

### Cut inheritance control

New Cut Inheritance controls located on the Display Options tab of the Edit View dialog allow users to determine whether or not the derived view inherits the cut properties of its parent view. Users can control inheritance for Breakout, Broken Section, and Slice operations.

There is a new option on the Broken View tool that allows users to prevent a cut operation on a child view from affecting its parent view.

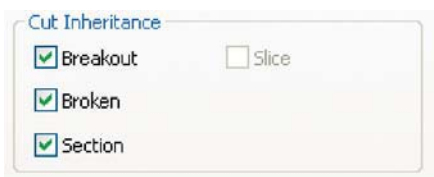

### Detail View cutout shape control

New options on the Detail View tool provide the option to select between a smooth or jagged cutout shape independently of the selected fence shape.

### Hidden lines on shaded views

Designers can now simultaneously select the shaded and hidden line style buttons on the view create and edit tools to create shaded views that also show hidden lines.

## Component Slice

A new Slice operation can be applied to an existing section or cut view to display sliced surfaces as a wire frame section through the geometry lying in the cut plane. This feature reduces the need to hide unwanted data in the background of Section Views and other views. There is a new context menu option in the browser to control which components are displayed as a section and which are displayed as a slice.

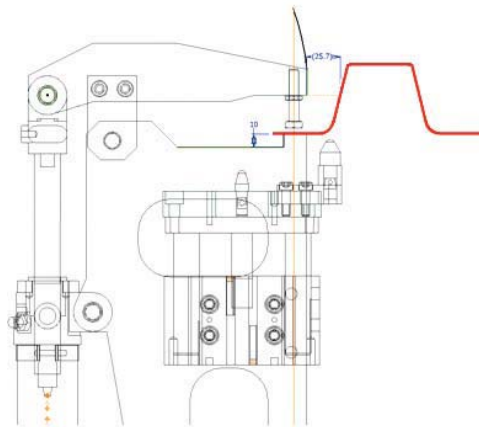

## Other Enhancements

- Hatching in isometric views
- Create section views using recovered sketch geometry
- Detail leader callout
- Rotate views by an absolute angle
- Crosshatch clipping around dimension text

## Revision Tables and Tags

Inventor 2008 introduces separate revision tables for drawings and sheets so designers can detail different components using separate sheets in a single drawing file and still have a separate revision table for each component. The sheet revision is stored in a new revision property.

Revision tables now have the same behavior as other tables in Drawing Manager including their own table edit tool and a separate revision table style. The edit tool for revision tables has specific behaviors to support revision semantics including a pencil icon that marks the active revision.

All of the tables used in Inventor Drawing Manager can now be rotated through 90-degree intervals.

# Technical What's New

Revision tables can be linked to drawing or model iProperties such as revision, date, approval, and description, and designers can access these document iProperties without closing the revision table edit dialog. Any changes made in the iProperties dialog are immediately reflected in the revision table. Conversely, inserting a new revision row increments the revision and updates the document iProperties.

REVISION HISTORY			
ZONE	REV	DESCRIPTION	DATE
	1	Released	11/10/2006
	2	ECCO 2663	11/10/2006
	3	ECCO 4539	11/10/2006

APPROVED	
BY	DATE
J. Smith	
B. Anders	
J. Smith	

Revision tags can now be associated to older revision numbers and the Style of Revision tags can be changed using the Edit Revision Tag dialog.

## Dimensions and Notes

### *NPT and tapered holes*

Drawings views containing taper-tapped holes display accurate results and correct display of thread lines. Hole notes support the new taper thread with additions for all hole combinations and hole notes provide full customization.

### *Linear dimension thread notes*

Thread and hole notes can now be formatted with a linear dimension style instead of the standard leader style.

### *Standards support*

New arrow head styles for half-filled, flared, and half-filled flared arrowheads to support the ESKD drawing standard.

### *Text styles for radial dimensions*

Dimension styles have been extended to radial dimensions so designers can control text wrapping in the same way as diameter dimensions.

## Other Enhancements

### *Concatenated iProperties*

Support for concatenated iProperties in Global BOM expressions, for example, "DIN 1026 U 30x15x980" where 980 is a custom iProperty linked to exported Length parameter.

## DWG TrueConnect

Inventor 2008 takes DWG interoperability to a higher level with DWG TrueConnect—new technology that provides direct read and write of DWG. Inventor drawings saved as DWG files provide view, plot, and measure with exceptional visual fidelity simplifying communication with other groups and supply chain partners. DWG TrueConnect combines the benefits of associative drawing views in Autodesk Inventor with the power and widespread acceptance of the DWG file format.

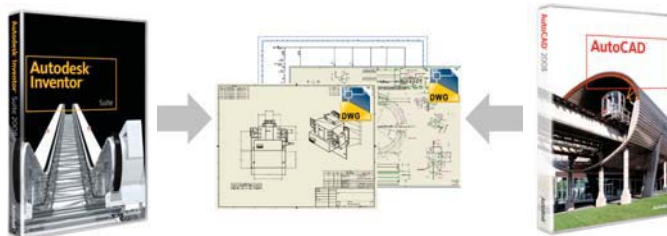

## View, Plot, and Measure Using AutoCAD

DWG files generated from Inventor contain an accurate AutoCAD representation of the Inventor view entities. Therefore, designers can use AutoCAD software to view, plot, and measure drawings created with Inventor Drawing Manager with exceptional visual fidelity. To support this functionality, AutoCAD® 2008 includes a new object enabler, which is also available for installation on AutoCAD® 2007. Inventor DWG files are not supported on earlier versions of AutoCAD.

## Saving Inventor Drawings as DWG Files

Inventor drawing views are represented as blocks in the DWG file, enabling designers to easily reuse view data in AutoCAD. Users can copy these view blocks into other drawings using AutoCAD® DesignCenter™ functionality or insert a view block in model space so that it can be referenced (xref) into another drawing.

DWG files created using direct DWG output are associative to the Inventor part and assembly models, so the View blocks in the AutoCAD DWG file will update if the view changes in Inventor.

## Opening AutoCAD DWG Files with Inventor

Designers can quickly open any AutoCAD DWG file in Inventor, and then view, plot, and measure the file contents. In addition all of the AutoCAD data is selectable for copy/paste so users can open an AutoCAD DWG file in Inventor and then copy and paste AutoCAD entities into an Inventor sketch.

Each AutoCAD layout (paper space) is represented as a sheet in the browser and all Inventor drawing commands are available. That means designers can place views and create annotations on a layout created in AutoCAD, and the Inventor data will coexist with the AutoCAD data.

# Technical What's New

Model space is represented as a read-only environment in Inventor with its own special entry in the browser. Users can control the background color and perform all viewing functions, including rotate if needed, since model space is a 3D environment. Users can select objects in model space for use with copy/paste and the measuring tools.

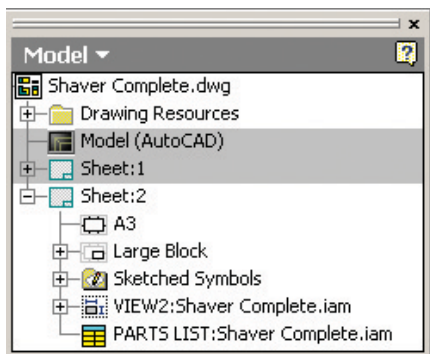

## Shared Objects

AutoCAD and Inventor can create their own objects in the same DWG file. For example, in AutoCAD designers can open a DWG file saved from Inventor and create new AutoCAD layouts. The new layouts will be displayed the next time designers open the file with Inventor.

Certain objects, including layers, blocks, styles, line types, sheet names, and sheet sizes can be edited in both applications. Any changes made to any of these objects in one application are reflected in the other. For example, deleting a layout in AutoCAD deletes the corresponding sheet in Inventor. Edits to a layer in AutoCAD are the same as edits to the layer in Inventor. Designers can edit a layer and change the line type from an Inventor line type to an AutoCAD line type. When reopened in Inventor, the Inventor layer will use the AutoCAD line type.

## AutoCAD Blocks in Inventor

With support for AutoCAD blocks in the drawing environment, designers can now reuse native AutoCAD blocks in Inventor drawing sheets. Users can also include 2D AutoCAD geometry as reference data in views of Inventor subassemblies.

## Additional Highlights

Designers can now load custom line types from AutoCAD line type files (\*.lin) and use these custom line types anywhere they used the standard Inventor line types in the past.

A new Plot On/Off property is included in the Drawing Manager layers, to match the AutoCAD Plot On/Off property. As with AutoCAD, setting the plot property to Off displays the layer, but it will not print or get published.

## DWG Import Tool

With existing releases of Inventor, the File Open command automatically launches the Import Wizard whenever a DWG file is selected. With Inventor 2008, selecting a drawing file (.dwg) in the Open dialog box provides users the option to either open the file directly, or import it using the existing Import Wizard. The default setting is Open.

*Note: Once a DWG file contains Inventor data, designers can no longer use the import wizard. Instead, they must open the file directly and use copy/paste to selectively import data into an Inventor document.*

## Comparison of Enhanced DWG Support with Translation

In almost all cases, direct DWG output provides a simpler, faster, and more maintainable workflow for saving Inventor drawings in the DWG format. Designers who rely on a process or workflow requiring the ability to edit AutoCAD geometric entities in the drawing views can still use the DWG translation tools provided with Inventor.

## Sketch Productivity

New developments in the 2D sketch environment will reduce the learning curve for new users and improve productivity for existing users by providing clearer feedback on constraint status. The new sketch edit tools reduce the time required to modify sketches while preserving unaffected constraints.

## Enhanced Sketch Constraints

Sketch constraints provide a powerful way to capture design intent in the 2D sketch. Working with constraints is simpler and easier with Inventor 2008. Multiple improvements reduce the effort required to build correctly constrained sketches, including diagnosing and resolving overconstrained conditions.

### Show Constraints tool

The Show Constraints tool now supports window select, reducing the time required to turn on specific constraint bars. When using the Show Constraints tool, the cursor now shows the number of constraints belonging to an item as soon as users point to it and highlights all the associated cross-constraints when other constraint bars are displayed.

### Improved constraint bar design

The constraint bars have been redesigned with an updated look and feel for improved visibility. Constraint bars are now fixed to the sketch plane during 3D rotate and a new placement algorithm to reduce screen clutter by minimizing overlap between constraints and their associated geometry.

# Technical What's New

## *Improved cross-highlighting*

When designers point to any piece of sketch geometry, all of the related constraints are illuminated in yellow so they can instantly see which parts of the sketch are constrained to the item. Alternatively designers can point to a specific constraint in a constraint bar and its associated or cross-constraint is highlighted in yellow so they can quickly tell which other constraints are related to it.

## *Display remaining constraints*

A new constraint feedback area appears at the bottom of the Inventor window when a sketch is active. This area provides continuous feedback of the number of constraints required for a fully constrained sketch so designers can quickly see how many constraints they need to add in order to fully constrain their sketch.

## *Constraint visibility control*

Located on the context menu in the graphics window, the new Constraint Visibility control provides a check box for each type of constraint so designers can control the visibility of each constraint type individually.

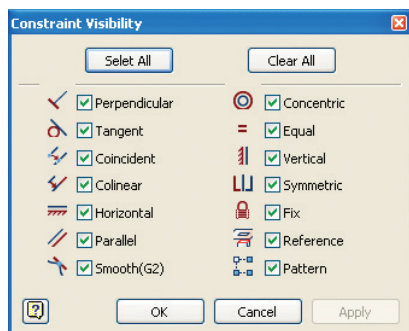

## *New Reference constraint*

A new Reference constraint is created when model geometry is projected onto the sketch plane to indicate that the geometry is reference geometry. Pointing to this constraint highlights both the sketch geometry and the referenced model geometry.

## **Sketch Edit Tools**

Inventor 2008 extends the existing tools for modifying sketch geometry. These tools allow users to modify constrained geometry while preserving unaffected constraints and dimensions.

## *Improved Move, Copy, and Rotate tools*

The existing Move and Rotate tools have been enhanced with dynamic preview, constraint, and dimension override capabilities, and direct access to the Precise Input tool. A new Copy tool is introduced although the Move tool can still be used to create copies.

## *Stretch tool*

Inventor already supports stretch operations when clicking and dragging underconstrained geometry. The new Stretch tool extends this capability so that users can stretch constrained geometry while preserving internal sketch constraints. The new Stretch tool provides more ways to stretch geometry with more predictable results than using constrained drag.

## *Scale tool*

The new Scale tool allows designers to change the size of 2D sketch geometry quickly by selecting the geometry then specifying a scale factor. Designers can make the geometry smaller (scale factor less than one) or bigger (scale factor greater than one).

## **Geometry Formatting Tools**

With Inventor 2008, designers can control the format of sketch geometry using the new Properties toolbar to modify color, line weight, and line style. In addition, importing AutoCAD geometry into an Inventor sketch preserves the format in the original DWG file. The Properties toolbar includes a toggle control for switching between the custom and default sketch attributes.

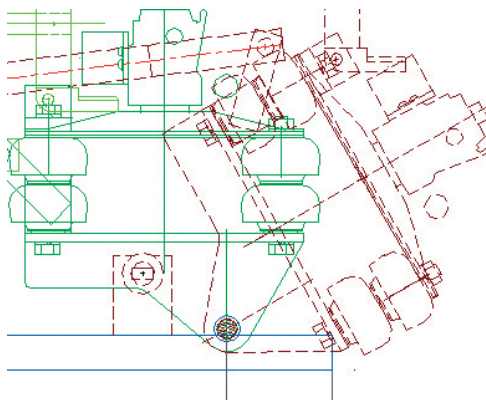

## **Enhanced User Interface**

The user interface for Inventor 2008 has been updated. These changes include enhancements to increase productivity as well as changes designed to reduce unnecessary visual differences between Inventor and AutoCAD that can cause confusion for people who work with both products.

# Technical What's New

## Productivity Enhancements

### Command Alias

Inventor 2008 introduces optional command aliases to provide faster keyboard access to commonly used tools. Typing the tool's command alias will invoke the tool immediately, while typing the first character displays a small pop-up window showing all the commands that start with the selected letter. Designers can select the desired command with the mouse or simply type the remaining character to invoke the tool.

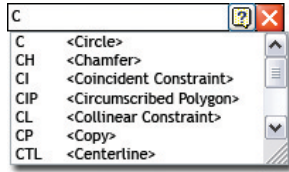

The Customize option has been enhanced to simplify the management of Shortcuts and Aliases and there is a new quick reference for available shortcuts.

### Repeat last command

Pressing the space bar repeats the last command to avoid reselecting the command each time.

## Application Consistency and Ease of Use

### Updated icons

The icons have been redesigned to improve consistency with AutoCAD, and controls are now compatible with the Microsoft® Windows® XP operating system.

### Tool tips and status text update

The Inventor cursor has a new tool tip option that displays command prompts in the line of sight so designers don't have to look at the bottom of the screen for the tool tip prompt.



### New File Access dialogs

There is a new Save As command for saving a copy of the active document with a new name. Unlike the existing Save Copy As command, the active document assumes the new name. When used with an assembly, the new command preserves the correct child relationships between the assembly and its components.

The Inventor Open dialog has been replaced by Open and New dialogs that comply with the standard Windows dialog definition. These dialogs, as well as those for Place Component, Save As, and Save Copy As, are resizable, retain directory and display settings, and provide standard access to Desktop, My Documents, My Network, and so forth.

## Shape Design

The shape manager gains new tools to improve complex design workflows and simplify the design of hydraulic and pneumatic components.

## Part Modeling Tools

### Area Loft

A new Area Loft option in the Loft tool allows designers to pick points along a center line and define either cross sectional area or scale factor at each point. This is primarily intended to simplify the design of hydraulic and pneumatic components but can also be used to place and scale sections at will in order to tweak the shape of the loft for aesthetic purposes.

Boundary conditions now influence the entire loft instead of a single section providing smoother, more organic shapes, and enhancements to surface behavior have been made to improve the reliability of Boolean, shell, and offset operations

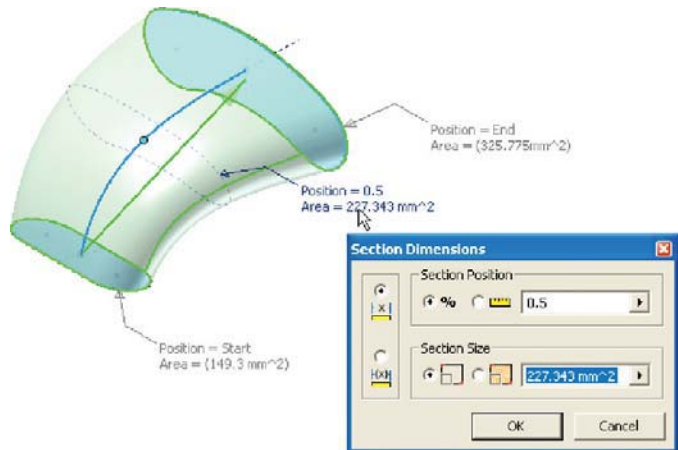

### New Bend Part feature

With the new Bend Part tool in Inventor 2008, designers can bend an existing part body around a selected sketch line allowing translated MDT bend features to be edited as native Inventor features.

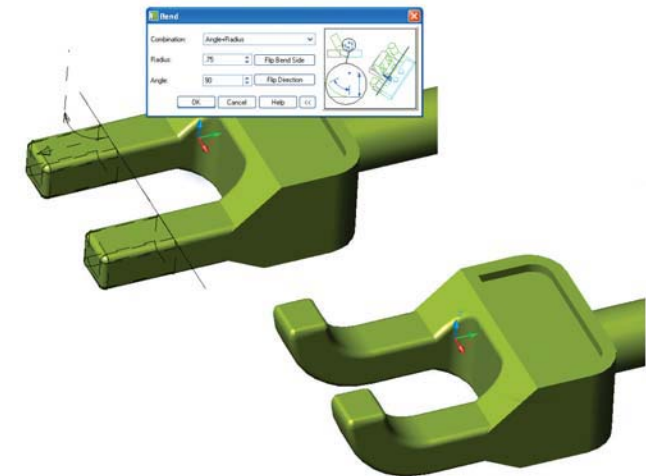

# Technical What's New

## *Tapped holes*

The existing hole feature is enhanced to accommodate taper tapped holes. Hole type combinations of drilled, countersink, and spotface are supported. Counterbore type is not supported with taper tapped as this option would produce an invalid thread.

## *Enhanced Revolve feature*

The Revolve tool has additional termination options that can be used with work planes and faces to control the extent of the resulting revolve feature.

## *New Helical Curve feature*

Helical curves can be created with the new Helical Curve tool, which includes support for natural and flat-end conditions.

## *Split face with 3D curve*

The Split tool can now be used with projected 3D curves to split the faces on which they lie.

## *Associative Project Cut Edges*

Sketch geometry created using the Project Cut Edges tool is now fully associative with a new Project Cut Edges node under the sketch node in the browser. Associativity can be broken by right-clicking on the Project Cut Edges node and selecting the Break Link option.

## *Associative cross-part Surface Copy*

An Enhanced Copy Object tool (formerly Promote) enables users to create associative cross-part copies of surface data that updates with changes to the part and assembly.

## *Direct Edit*

Designers can now use 3D Grips directly by clicking on a model face. Editable faces are indicated by the display of a green spherical glyph, which designers then select to activate the edit mode. New application options give users more control over 3D Grip behavior in the presence of dimensional and geometric constraints. The default behavior has been changed so that the tool will not affect existing dimensional or geometric constraints. Users can also turn off 3D Grips if they don't use them.

## **Measure and Analysis Tools**

### *Enhanced Cross Section tools*

The Cross Section Analysis tool has multiple enhancements in Inventor 2008. In addition to selecting a face and parallel offsets, designers can now select multiple work planes or model faces in any orientation and the tool calculates the moment of inertia for each section with a glyph showing the centroid for the moment of inertia.

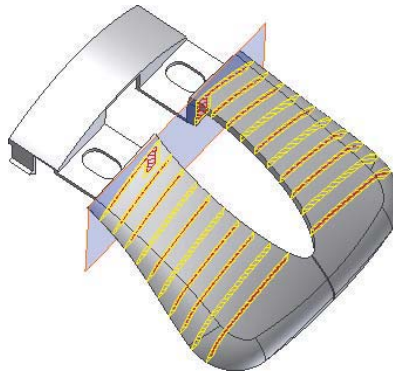

### *New Region properties*

A new Region Properties tool is now available while in sketch mode that calculates the moment of inertia of sketch loops with respect to the sketch origin.

### *Additional Surface Analysis options*

The Gaussian Curvature Analysis tool is now called the Surface Analysis tool with two new options that create a colored display of the mean and maximum curvature values in the U and V directions.

A new Field Chooser for controlling the information displayed in the Results table and an export option can be used to output the results to a text file for further analysis.

## **Quality and Performance**

Changes are made to support operations on tolerant models so designers can use low-tolerance imported geometry in Inventor models without compromising the creation of drawing views and other dependent data.

The Fillet shell and boundary patch technology has been enhanced to improve general robustness and address problems reported by users.

The faceting algorithm has been optimized to improve display regeneration performance during zoom operations.

# Technical What's New

## AliasStudio Interoperability

New capabilities for importing AutoCAD surface and solid data combined with new DWG export from Autodesk® AliasStudio™ software gives designers a quick and reliable way to transfer concept designs into the Inventor application. Supported entity types include 3D surfaces, 3D bodies, polygon meshes and polylines.

The import wizard maps AutoCAD layers directly to Inventor composite features and there is now a choice of importing wires as 3D elements or projecting them to a 2D sketch plane. The imported 3D surfaces can be manipulated in the construction environment and quickly incorporated into 3D Inventor part models using the Sculpt tool.

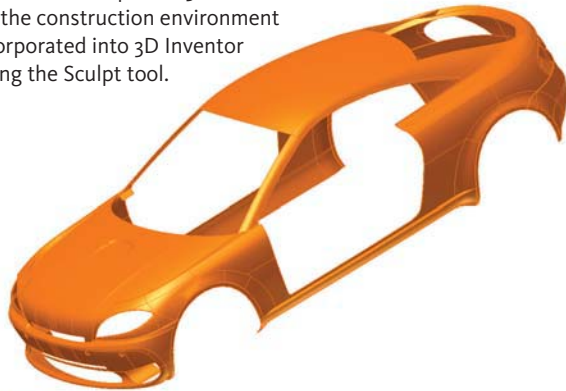

## Dynamic Simulation

Available in *Inventor Professional* and *Inventor Simulation Suite*

Enhancements to dynamic simulation are focused in two primary areas: first, to encourage more use of simulation by reducing the time required to set up and perform a simulation, and second, to support analysis of the stress on parts at different points, or time steps, in the simulation cycle.

### Automatic Joint Creation

The setup process for performing a dynamic simulation is dramatically simplified with the introduction of automatic joint translation. Assembly constraints in the assembly model are used to identify the rigid bodies and joints that define the kinematic state of the system. The resulting joints are generated automatically with full associativity to the assembly model.

In addition, the translation process searches for extraneous degrees of freedom—such as fasteners with unconstrained rotation—to minimize the number of bodies in the simulation. Users have the option to override all adjustments made by the translator when necessary, or to turn the translator off and create joints manually.

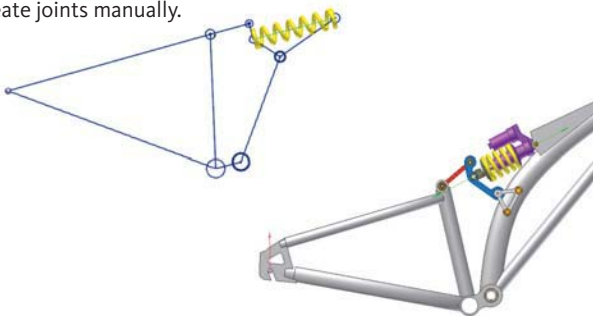

## Stress Analysis Integration

Integration of the dynamic simulation and stress analysis environments is enhanced to provide more control over which loads are included in the FEA (finite element analysis). A new group in the dynamic simulation browser shows all the components to be included in the stress analysis data export.

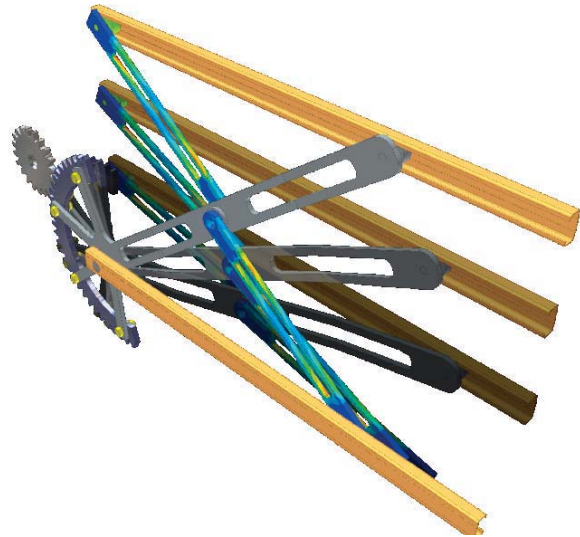

There is a new column of check boxes in the output grapher for marking multiple time steps for export to stress analysis. All components that are included in the export group are evaluated at the indicated time steps, expediting the comparison of stresses at different times in the operating cycle.

To simplify the process of identifying load faces, all components that are not marked for export are made transparent.

### Export Trace Curves to a Sketch

Paths generated from motion studies can be exported to a sketch for use in modeling.

### Enhanced 2D Contact Capabilities

The three 2D contact joint types in Inventor 11 have been consolidated into a single 2D contact joint type to minimize the need to choose the reference geometry type while still retaining the performance benefit of a 2D contact joint over a more generalized 3D contact joint.

### Usability Enhancements

Numerous usability improvements have been implemented to remove inconsistencies between the dynamic simulation and modeling environments. In particular, face selection is easier with enhanced face selection view, highlighting of selected load faces, and improved use of transparency.

# Technical What's New

## Finite Element Analysis

Available in Inventor Professional and Inventor Simulation Suite

### Stress Analysis for Thin Wall Parts

A new thin shell element provides faster analysis than standard 3D tetra elements when analyzing thin-walled or constant-thickness parts.

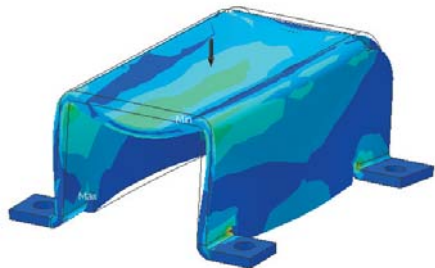

### Feature Suppression for Stress Analysis

The Stress Analysis environment now has the ability to maintain a unique set of feature suppressions that are independent of the part's original part or sheet metal environments. This allows simplifying geometry to provide more efficient meshing.

### Multiple Time Step Analysis

Analysis based on loads at multiple time points in a dynamic simulation cycle can now be exported at once, eliminating the need to switch back to dynamic simulation for each time step. Users can quickly view the analysis output at each time step and see the assembly update to the corresponding position.

## Frame Design

The design of welded frames using skeletal reference geometry is easier and faster in Inventor 2008. This enables the design of larger, more complex frames and simplifies the modification of frame member characteristics during the design process.

### Parametric Frame Layout

With Inventor 2008, frame generator adopts a new layout technology similar to that used in tube and pipe routing. Based on the generation of a 3D reference wireframe—called the Frame Reference Model—the new approach provides full-model associativity and lets designers use any combination of sketch, part, and assembly geometry. In addition, designers can now reorganize individual sections into separate subassemblies, using Promote and Demote commands, to reflect the actual manufacturing sequence.

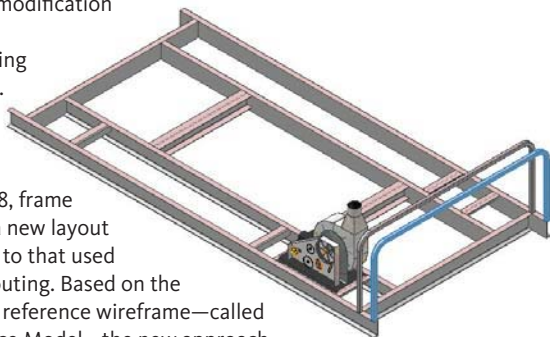

## Improved Cut Treatments

Designers can now create frame designs based on geometry from different parts and assemblies with full support for end treatments irrespective of the origin of the skeletal geometry. Cut treatments are displayed as separate items in the browser with their own custom properties for extend length and manufacturing notes.

## Improved Frame Editing

Substituting a frame section with a different standard, type or size is simpler and faster. The Change tool has new lock options allowing designers to quickly edit multiple section pieces at the same time—even if there are differences in the section or size in the group that users want to edit.

## Bent frame members

A new Merge option on the Insert tool creates single swept frame elements when working with edges.

## Other Enhancements

### Standards

Frame generator includes additional standards support including GOST and AFNOR sections.

### Performance

Performance is substantially improved, especially when working with large frame designs, and the 3D preview is also faster.

## Design Accelerators

Several of the Component Generators and Mechanical Calculators have been updated with new interfaces and interactive dynamic preview.

## Shaft Generator

The Shaft Generator has been redesigned to incorporate full 3D preview with optional 2D diagrammatic preview. The 3D preview includes 3D Grips, allowing designers to interactively alter the length and diameter of individual elements. Using the Element area of the generator dialog, designers can quickly select the element type—cylinder, cone or n-sided—as well as specify internal geometry, end treatments, and element features such as keyways, through holes, and retaining rings. Shaft parameters are automatically transferred to the calculations tab enabling designers to interactively define loads, bending moments, and torques then calculate rigid stress analysis under the set conditions.

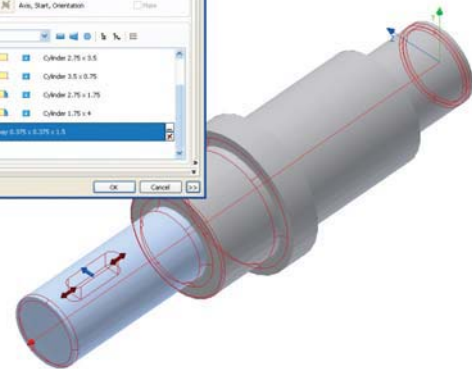

# Technical What's New

## Roller Chain Generator

Design roller chain drives using a comprehensive library of roller chains, sprockets, and idler wheels. The enhanced generator's preview displays the dimensions and power curve for each chain in the library to help users select the right chain for the power and speed requirements of the transmission.

The chain drive generator includes a full 3D preview of the chain and sprockets with 3D grips for changing sprocket size and location. Comprehensive options for controlling sprocket placement include fixed to coordinates or to the axis of a shaft, free sliding as well as driven by chain length with support for linear and arc slide geometry.

Comprehensive options for controlling sprocket placement include fixed coordinates, locked to the axis of a shaft, free sliding and driven by chain length with support for linear and arc slide motion.

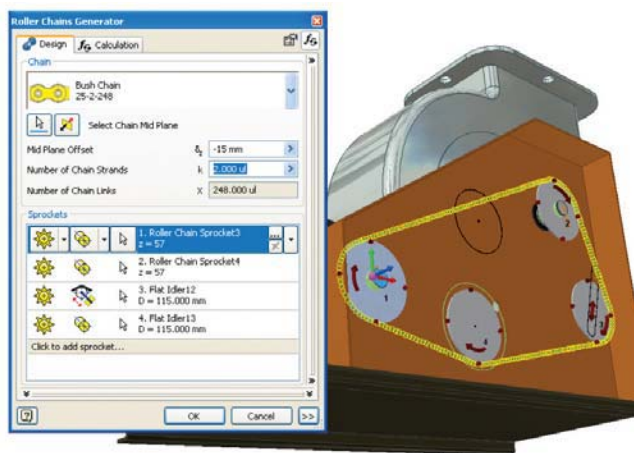

## Spring Generators

Newly enhanced generators for compression, tension, and Belleville springs provide streamlined workflow for spring design and, in the case of Belleville springs, give users 3D grips for interactively controlling the number of springs inserted into the assembly.

## Beam and Column Calculator

The Beam and Column calculators are combined into a single calculator, which users can now access directly from the frame generator menu and populate the section parameters by selecting the frame component in the graphics window. Users can also enter parameters manually to investigate the design characteristics of alternative cross sections and materials.

## Limits and Fits Calculator

The Limits and Fits calculator has been enhanced with improved graphics that show the tolerance overlap graphically for each limit zone.

## Assemblies

Enhancements in the assembly design environment address requirements of customers using skeletal design techniques with large assemblies.

### Improved Design Doctor™ Feedback on Conflicting Constraints (AUGI #1)

During Hospital treatment of a sick constraint, the references are highlighted in a "burn-through" fashion, to make them more visible and easier to locate.

### Multiple File Open and Place (AUGI #9)

During File Open and Place, multiple files can be selected at the same time, reducing the time to introduce new components into an assembly.

### Default Level of Detail

There is a new applications option to provide a systemwide default LOD for use with the File Open and Component place tools. The initial setting on install is Last Active, which uses the last saved LOD setting for a given assembly file. Alternatively, users can change the setting with the Options panel, during Open or Place.

### Infer iMates from Constraints

There is a new Infer iMate command located on the constraint context menu. This command generates an iMate from the constraint information and replaces the constraint with the iMate result in the same step. The tool supports multiselection so users can convert multiple constraints in a single step.

### Optimize Option for Selection Prehighlight

There is a new option to activate an optimized selection highlight algorithm, which provides improved prehighlight performance when there are a large number of objects within the graphics window.

## Skeletal Modeling

Derived Assemblies support object level tracking in order to minimize unnecessary updates and provide a more robust Skeletal Modeling workflow.

It's now possible to selectively derive exported objects from a base component by marking new objects for export using the Derive dialog, and parameter linking is now supported between any combination of part, sheet metal, assembly, or weldment.



# Technical What's New

## Derived Assembly

The Derived feature has significant user interface enhancements, including:

- Graphical selection
- Multiselect and direct status adjustment
- Mirror and scale in Derived Assembly
- Ability to mark objects for export, that were not already exported

## Delayed Migration

Migration is delayed until necessary. Operations such as File Open will no longer incur the cost of migrating data automatically, reducing the need for lengthy batch migrations when upgrading to Inventor 2008.

Delayed migration will only work with files created in Inventor 11.

## Other Enhancements

- Reorder constraints in browser
- Assembly sketch redefine
- Globalized keywords in iAssembly tables

## Flanged and Welded Pipe Styles

Available in Inventor Professional and Inventor Routed Systems Suite

### Flanged Pipe Runs

There is a new tube and pipe style for flanged pipe runs that populates pipe runs with flanged fittings including automatic placement of gaskets. The flanged pipe styles inserts the appropriate flange fittings based on the type of joint—inserting two flanges and a gasket for a simple joint between two pipe segments and automatically inserting the required flange between a pipe and a fitting.

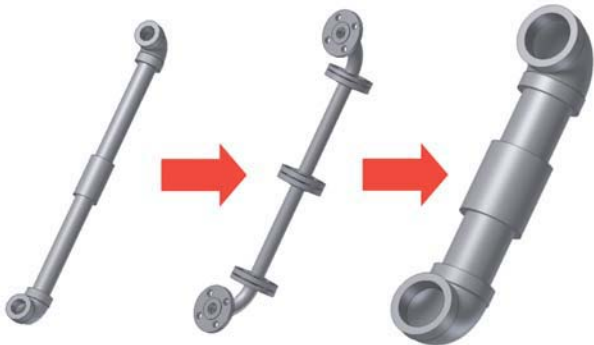

### Butt Weld Pipe Runs

A new tube and pipe style for butt welded pipe runs populates pipe runs with welded joints and adjusts pipe lengths to create the correct gap allowance for welds.

## Tube and Pipe Styles Editor

The styles editor has been redesigned to reduce the time needed to create and maintain tube and pipe styles. The new editor includes a browser to display the different styles in the library, user defined categories, and support for copying styles. Each style has its own rules tab that displays only the rules required by the selected style. The revised editor supports the new flanged and welded pipe styles and includes a new capability for importing and exporting tube and pipe styles for sharing styles with other users. Users can now import export runs from the Local Runs Template and import them into the Master Runs Template to be used when creating new pipe runs.

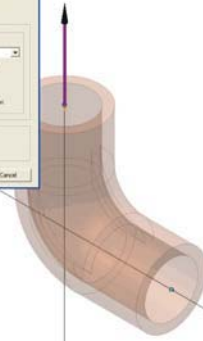

## Ribbon Cables

Available in Inventor Professional and Inventor Routed Systems Suite

Inventor 2008 supports the insertion and routing of ribbon cables with full control over the shape of the cable, including the ability to define multiple twists and folds.

### Ribbon Cable Design

Quickly place ribbon cables by selecting a ribbon cable from the cable and harness library and identifying the start and end connectors in the model. The Create Ribbon Cable tool creates a ribbon cable between the connectors. Users can add or delete folds and twists using work points to control their position on the ribbon cable.



# Technical What's New

## Cable Connector Authoring

Authoring of cable connectors has been added to the Content Center publishing tools so users can define cable connectors with configurable pin patterns and wire direction.

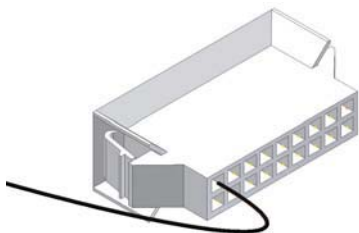

## Connector Placement on Nailboard Drawings

With Inventor 2008 users can quickly create nailboard drawings with connector depictions for manufacturing. Simply define the default offset, orientation, and rendering style to be used using the Nailboard settings. Inventor uses these values to automatically add the connectors to the drawing.

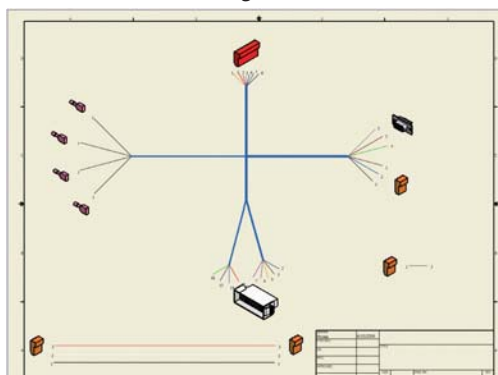

## Cable and Harness Performance/Capacity

- Improved performance when creating or deleting multiple sweep features
- Improved performance and capacity for centerline recovery in the drawing environment

## Import Export

### Import

New import capabilities are provided for

- Import 3D surface data from AliasStudio using DWG files
- Import 3D points to a sketch
- Automatic Healing
- Performance and optimization

### Export

Color for Solids and Surfaces

This enhancement provides the ability to control color overrides for CE solids, surfaces, and part modeling surfaces.

New export capabilities

- Surfaces to STEP
- Face and feature color

## Construction Environment

The Construction Environment is enhanced to simplify the analysis and repair of problems encountered in imported data and to enable workflows using surfaces and wire geometry.

Enhancements include the following:

### Construction Environment

- Simplified data transfer to and from Construction Environment

### Composite Data

- Cross part promote
- Move data between features
- 3D intersection curve

### Drawing Creation

- Performance with STEP files
- Drawing views of "bad" data
- Slice components view

## Inventor Studio

A variety of productivity enhancements have been added to Inventor Studio. These include new positional representation start states, measure command, most recently used values, unit value retention, and faster-to-specify input.

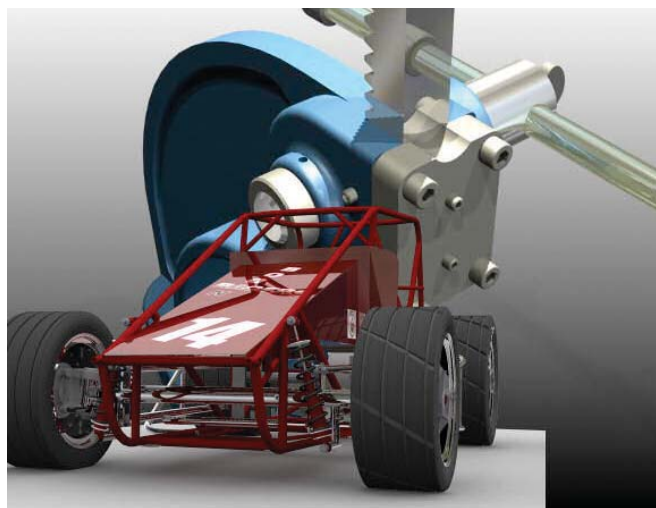

The improved scaling of diffuse and bump maps, render preview frame, alpha channel output for PNG formats, and support for TIFF and GIF image formats provide additional control over the final render and output type. Two new global lighting styles make it easier to get realistic renders. And the Illustration output render style provides the ability to create imagery for technical documentation.

# Technical What's New

## DWF Publishing and Design Review

Inventor 2008 includes DWF™ publishing<sup>1</sup> for creating DWF files containing drawing sheets, 3D part and assembly models, Bill of Materials (BOMs), and the results of FEA analysis.

## Comprehensive 2D and 3D Publishing

Publishing includes full support for Inventor drawing sheets and 3D models with comprehensive options for using positional representations, design views, and active Level of Detail representations. DWF output from Inventor also supports iParts and iAssemblies, allowing complete product family definition in one DWF file.

## Autodesk Design Review

Inventor 2008 is fully compatible with Autodesk® Design Review software for a simple and effective solution to track, manage and verify multiple markups and design changes throughout the design review process. Users can overlay DWF markups directly onto Inventor drawings, provide status and make changes and then republish or round-trip those changes back to the design reviewer to complete the process.

*<sup>1</sup>These features were first released in the Inventor 11 DWF Extension which was released to subscription customers in May 2006.*

## Security Management

The DWF security options provide increased control over how design data is published and shared with users in other organizations. Inventor 2008 includes optional password protection for read and options for disabling measure and print functions in published files.

## Bill of Materials Output

Easily share accurate BOMs information with manufacturing, purchasing, and suppliers by publishing the BOMs in the same file and including detailed property information such as material and mass for each item in the BOM. Bill of Materials options allow users to select between publish the parts-only BOM or a detailed assembly structured BOM.

## Work Instructions

DWF Publishing improves the effectiveness of electronic manufacturing documentation such as detailed step-by-step assembly and work instructions because users can create animated DWF files by publishing directly from Inventor Presentation files.

## Content Center

### BOM Document Setting Support

Custom BOM settings, such as default BOM structure type, unit quantity, and so forth, made in a part's Document Settings are now preserved when custom parts are published in the Content Center. In addition, the part templates associated with Inventor standard content can be replaced in order to modify their default BOM settings.

### AutoDrop On-Off option

A new AutoDrop On-Off button located on the toolbar in the Place From Content Center dialog allows users to easily switch the AutoDrop feature on and off. When selected On, AutoDrop automatically selects the appropriate part size for the selected location, inserts the part and creates the correct assembly constraints. When selected Off, AutoDrop is replaced by the dialog for the selected content family, allowing users to select the right size, place it in the assembly, and manually insert the appropriate constraints.

The selected AutoDrop mode can be temporarily overridden, or reversed, at any time by holding down the Alt key while double-clicking on the required content family. The selected AutoDrop mode as well as the Alt key override also works when placing content using the Favorites mode in the Inventor browser.

### Side-by-Side Installation

With Inventor 2008 it will be possible to support content for multiple versions of content on the same server, allowing Inventor 11 and Inventor 2008 systems to operate in parallel. (This capability does not apply to releases before Inventor 11.)

### Improved Library Configuration

Read-Write user libraries are generated during the installation process to provide a fully functional Content Center environment at the completion of installation. This avoids the additional postinstallation steps that were needed in Inventor 11 before you could modify content or publish custom parts.

### Performance Improvements

Performance has been improved in almost all areas of the Content Center, including initial startup, preview rendering, generation after placement, searching using component criteria, applying filters, switching projects, and the Content Center editor.

# Technical What's New

## Mechanical Desktop Compatibility

The Mechanical Desktop® translator has been enhanced to increase the number of Mechanical Desktop models that can be imported into Inventor. The enhancements are listed below.

### *Accurate translation of:*

- AMBEND Features
- AMCOMBINE multibody features
- AMREVOLVE with terminations
- Insert and midpoint constraints
- Feature color

### *Hidden Inventor views are now created for:*

- Mechanical Desktop base section views
- Mechanical Desktop deleted parent views

## Stay Up to Date

Autodesk gives you more. Gain access to technical expertise, utilize training and support programs direct from Autodesk, learn about the latest product releases and give us your feedback about the Autodesk Inventor products. Not only does Autodesk want to help you use Inventor more effectively but we want to make sure Inventor is working effectively for you.

## Subscription

Log in to the Subscription Center to receive product updates, log and view support requests, or take e-Learning courses. A valuable component of Autodesk® Subscription, e-Learning provides a continually expanding curriculum of short training.

## Product Updates

If you experience an issue with Inventor 2008 that has already been solved in a service pack or hotfix, a dialog box will appear when you submit the problem to Autodesk, enabling you to immediately install the new service pack or hotfix.

## Feedback

Inventor 2008 customers can provide feedback to the Inventor 2008 development team through several different avenues:

- Provide tips or join newsgroups at [www.autodesk.com/inventor](http://www.autodesk.com/inventor)
- Leave a suggestion or log an issue with Autodesk employees that you meet at events or even during conversations with product support
- Talk with your Autodesk Authorized Reseller and support staff

Your input is crucial to our success, and we look forward to receiving your suggestions.

## Conclusion

We thank you for your continued support of the Autodesk Inventor family of products and hope you feel we are listening to your needs. We developed the new and enhanced functionality to make you more productive, your company more competitive, and return true value to your bottom line.



**applied** engineering technology, inc.

763-420-6600

1-866-941-6600

[www.ae-solutions.com/autodesk](http://www.ae-solutions.com/autodesk)

[sales@ae-solutions.com](mailto:sales@ae-solutions.com)

Autodesk, AutoCAD, AliasStudio, Autodesk Inventor, DesignCenter, Design Doctor, DWF, DWG, DXF, Inventor, and Mechanical Desktop are registered trademarks or trademarks of Autodesk, Inc., in the USA and/or other countries. All other brand names, product names, or trademarks belong to their respective holders. Occasionally, Autodesk makes statements regarding planned or future development efforts for our existing or new products and services. These statements are not intended to be a promise or guarantee of future delivery of products, services, or features but merely reflect our current plans, which may change. Purchasing decisions should not be made based upon reliance on these statements. The Company assumes no obligation to update these forward-looking statements to reflect events that occur or circumstances that exist or change after the date on which they were made. Autodesk is not responsible for typographical or graphical errors that may appear in this document.

© 2007 Autodesk, Inc. All rights reserved.